

M-D Pneumatics™

EQUALIZER® RM

Rotary Positive Blowers

Models: • 4606 • 4609 • 4612
• 6012 • 6016 • 6024

Bi-directional Rotation

17 Series - Horizontal Air Flow

46 Series - Vertical Air Flow

Designed to be interchangeable with equivalent Roots™ RAM™ models, **EQUALIZER RM** rotary positive blowers offer many distinct advantages when compared to other brands:

Helical Gearing

EQUALIZER RM blowers are timed with hardened, precision helical gears, keyed to the rotor shafts. Helical gearing reduces backlash and mechanical noise as compared to spur gears offered by other manufacturers. Keyed interference fit reduces the risk of slippage of the gear on the shaft and loss of timing, one of the leading causes of blower failure.

Single Piece Housing

Every **EQUALIZER RM** blower includes a housing constructed of a single piece of precision machined cast iron, rather than a two piece housing which is subject to misalignment and loss of operating clearances.

Rotors with Integral Shafts

EQUALIZER RM blowers include precision machined and dynamically balanced ductile iron rotors with large, integrally cast shafts to provide a single unitized rotor to prevent clash as a result of the impeller moving on its shaft.

Positive End Clearances

End clearances are **positively established** and **locked in** at the blower gear end, eliminating the risk of shifting end clearances. End clearances are not “floating”, and allowing incidental contact between rotors and end plates. “Floating” end clearances can result in unnecessary rotor and end plate wear, reducing flow performance and shortening overall blower life.

Polished Sealing Surfaces

All shaft surfaces in contact with sealing members are polished to reduce seal wear and risk of leakage.

Individually Tested

Every **EQUALIZER RM** blower is factory tested to assure you of the highest quality. Tuthill Vacuum & Blower Systems goes the distance to insure that your blower meets our rigid ISO 9001 registered quality standards.

ISO 9001 Registration

EQUALIZER RM blowers are manufactured under Tuthill Vacuum & Blower Systems' ISO 9001 registered quality assurance program, the first American manufacturer of rotary blowers to gain such international recognition.

Versatility

Flow configuration is field convertible from horizontal to vertical flow, or vice versa without replacement of end plates.

Metric Availability

All **EQUALIZER RM** blowers are available with metric drive shaft and process connections.

Worldwide Sales and Service

With sales offices and service facilities located on six continents, you can be assured of availability and service for your **EQUALIZER RM** blowers.

Material Specifications:

Housing: Cast iron

End Plates: Cast iron

End Covers: Cast iron

Rotors: Ductile iron

Shafts: Ductile iron cast integrally with rotors

Bearings: Gear end - Double row ball

Drive end - Cylindrical roller

Drive Shaft: Ductile iron cast integrally with drive rotor

Gears: Heat treated alloy steel, helical cut

Seals: Lip and piston ring labyrinth type on rotor shafts;

lip seal on the drive shaft

Lubrication: Oil splash system, both ends

Gastight and Elevated Pressure Designs

Refer to Tuthill Vacuum & Blower Systems 4000/5500 PD PLUS® and 4100/5600 AcousticAir™ specification sheets for additional information on these features.

Model Size	Max. Press. PSI	Max. Vac. (in. Hg)	Maximum RPM	Displ. CFR
4606	18	16	4000	.171
4609	18	16	4000	.249
4612	15	16	4000	.328
6012	15	16	3000	.587
6016	15	16	3000	.783
6024	10	16	3000	1.174

LEADING THE SEARCH FOR NEW SOLUTIONS



TUTHILL
Vacuum & Blower Systems

4840 West Kearney Street, P. O. Box 2877
Springfield, Missouri USA 65801-2877
Tel 417 865-8715 800 825-6937 Fax 417 865-2950
<http://vacuum.tuthill.com>



Performance

Pressure performance is based on inlet conditions of 14.70 PSIA and 70° F.

Vacuum performance is based on inlet temperature of 70° F and discharge pressure of 14.70 PSIA.

In conjunction with our program of continuous testing and upgrading, all specifications are subject to change without notice.

All data are approximate. Request a quotation for your specific application.

Horizontal Flow (17 series)

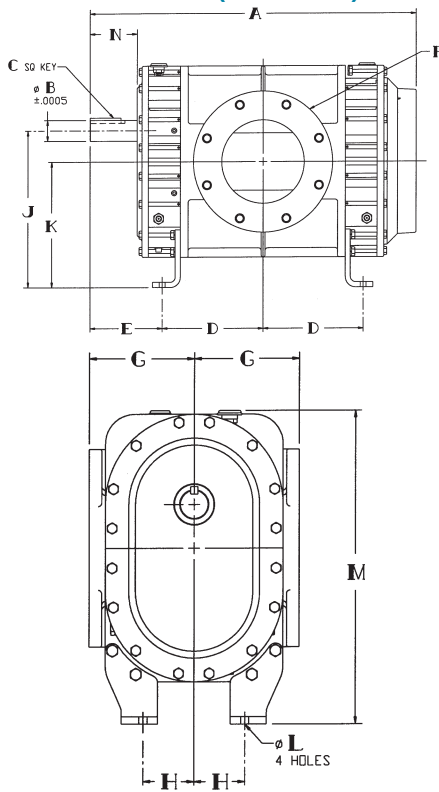

Vertical Flow (46 series)

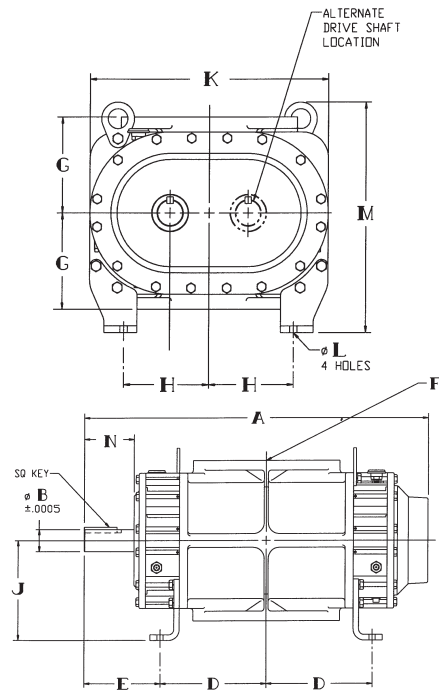

Blower Model	Replaces	Speed (RPM)	5 PSIG		8 PSIG		10 PSIG		12 PSIG		15 PSIG		18 PSIG		Max. Vacuum		
			CFM	BHP	CFM	BHP	CFM	BHP	CFM	BHP	CFM	BHP	CFM	BHP	" Hg	CFM	BHP
		1150	109	5.4	85	8									11	82	5.8
		1750	211	8.2	188	12	175	15	163	17					14	158	11
4606	Roots™ 406 RAM™	2950	417	14	393	20	380	25	368	29	352	36			15	353	19
		3500	511	16	487	24	474	29	462	35	446	43	432	50	16	437	24
		4000	596	19	573	28	560	34	548	40	532	49	517	58	16	522	27
		1150	175	7.4	145	11	129	14							12	130	8.5
		1750	324	11	295	17	278	21	263	24					14	257	15
4609	Roots 409 RAM	2950	623	19	594	28	577	35	562	41	542	51	523	61	16	530	28
		3500	760	22	731	34	714	41	699	49	679	60	660	72	16	667	33
		4000	885	26	855	39	839	47	823	56	803	69	785	82	16	791	38
		1150	245	9.3	210	14	190	18	173	21					13	179	12
4612	Roots 412 RAM	2950	836	24	801	37	781	45	763	53	739	66			16	725	36
		3500	1016	28	981	43	961	53	943	63	919	78			16	905	43
		4000	1180	32	1145	50	1125	61	1107	73	1083	90			16	1069	49
		1150	465	16	409	25	378	31	350	37					14	337	22
6012		1450	641	20	586	31	554	39	526	46	487	57			15	490	29
		1750	817	24	762	38	730	47	702	56	663	69			16	641	37
		2400	1199	33	1143	52	1112	64	1083	76	1045	95			16	1023	51
		3000	1551	42	1495	65	1464	80	1436	95	1397	119			16	1375	64
6016	Roots 616 RAM	1150	638	21	568	33	529	41	494	48					14	478	28
		1450	873	26	803	41	764	51	728	61	680	76			15	684	38
		1750	1108	32	1038	50	999	62	963	74	915	92			16	888	49
		2400	1617	44	1547	68	1508	85	1472	101	1424	126			16	1397	67
6024	Roots 624 RAM	3000	2086	55	2017	85	1978	106	1942	126	1894	157			16	1866	84
		1150	983	31	885	48	830	60							13	798	39
		1450	1335	39	1237	61	1183	76							14	1111	53

Dimensions

Model	Series	A	B	C	D	E	F	G	H	J	K	L	M	N
4606	17 46	20.00	1.500	.375	4.75	5.69	4" NPT	6.00	2.50 4.75	11.30 7.50	9.00 14.25	.438	16.62 13.50	3.69
4609	17 46	23.00	1.500	.375	6.25	5.69	4" NPT	5.50	2.50 4.75	11.30 7.50	9.00 14.25	.438	16.62 13.00	3.69
4612	17 46	26.00	1.500	.375	7.75	5.69	6" FLG	5.50	2.50 4.75	11.30 7.50	9.00 14.25	.438	16.62 13.00	3.69
6012	17 46	27.63	1.562	.375	7.31	7.44	8" FLG	9.00	4.00 6.00	15.00 9.00	12.00 18.25	.750	23.37 17.37	4.56
6016	17 46	31.63	2.000	.500	9.75	7.00	8" FLG	7.25	3.50 6.50	15.00 9.00	12.00 18.25	.562	23.37 17.37	4.56
6024	17 46	39.63	2.000	.500	13.75	7.00	10" FLG	7.25	3.50 6.50	15.00 9.00	12.00 18.25	.562	23.37 17.37	4.56

Values shown are approximate and should not be used for construction.

Certified drawings are available through your local Tuthill Vacuum & Blower Systems Sales Professional.

Your Local Tuthill Vacuum & Blower Systems Sales Professional:



TUTHILL
Vacuum & Blower Systems

4840 West Kearney Street, P. O. Box 2877
Springfield, Missouri USA 65801-2877
Tel 417 865-8715 800 825-6937 Fax 417 865-2950
<http://vacuum.tuthill.com>

