

MOTOR W/SLIDE BASE 1800 RPM, 230/460 V, 3 PH, 60 HZ		
HP	FRAME	TYPE
3	182T	ODP
5	184T	TEFC
7 1/2	213T	TEXP
10	215T	SEVERE DUTY TEFC
15	254T	SEVERE DUTY TEXP
20	256T	
25	284T	

BLOWER	A	B	C	D
3206-84/85	2 1/2 NPT	12 5/16	4 1/2	10
3210-84/85	3 NPT	10 5/16	4	11

APPROXIMATE WEIGHT

BASE, DRIVE, & GUARD - 218 LBS

BLOWER - \_\_\_\_\_ LBS

MOTOR & SLIDE BASE - \_\_\_\_\_ LBS

---

TOTAL WEIGHT - \_\_\_\_\_ LBS

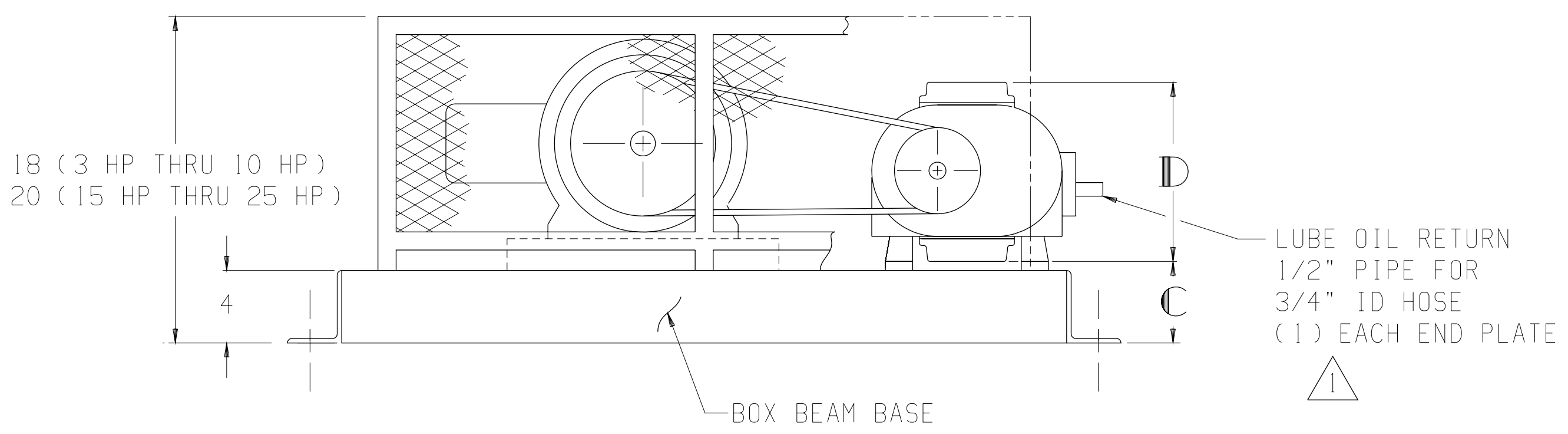

NOTE:

⚠ EXTERNAL LUBE SYSTEM MUST BE LOCATED SO THAT SLOPE FROM BLOWER DRAIN TO TANK INLET IS NOT LESS THAN 1'-0" IN 6'-0".

THIS OUTLINE APPLIES TO THE BLOWERS & MOTORS SHOWN IN TABLES



**TUTHILL**  
Pneumatics Group Springfield, Missouri USA

BASE MOUNTED OUTLINE B3200VV2-L

SIZE: C2	
DR JS 10-31-90	CH CM 11-1-90