

LTR	REVISION	DATE	DR	CH
D	1) SILENCERS WERE 29551; 2) REMOVED 4014 (ECN 4767)	7-28-06	CM	CM

BLOWER	INTAKE SILENCER	B	C	D	E	F
4006 & 4009	17300-025	2 1/2 NPT	56 7/8	61 7/16	23	7
	17300-030	3 NPT	57 5/16	61 7/8	29	7
4012	17300-025	2 1/2 NPT	57	61 9/16	23	7
	17300-030	3 NPT	56 15/16	61 1/2	29	7
	17300-F40	4 FLG	58 1 1/16	64 7/16	35	7 1/2

BLOWER	A	G
4006-46E/81E	14 7/16	3 NPT
4009-46E/81E	15 15/16	3 NPT
4012-46E/81E	17 7/16	4 NPT

FILTER (OPTIONAL) <sup>2</sup>	H	J
26512-025X	10 13/16	8 1/2
26512-030X	11 9/16	8 13/16
26512-F40X	17 1/16	13 5/16

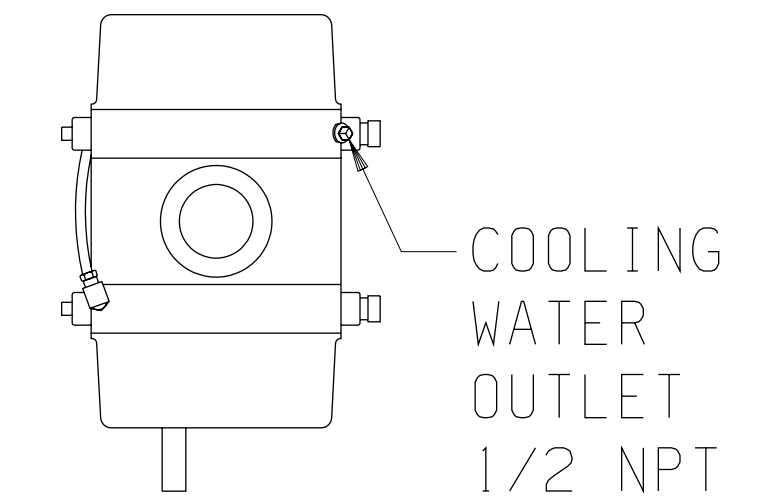

MOTOR W/SLIDE BASE 1800 RPM, 230/460 V, 3 PH, 60 HZ		
HP	FRAME	TYPE
15	254T	ODP
20	256T	TEFC
25	284T	TEXP
30	286T	SEVERE DUTY TEFC
		SEVERE DUTY TEXP

THIS OUTLINE APPLIES TO THE BLOWERS AND MOTORS SHOWN IN TABLES

APPROXIMATE WEIGHT

BASE, DRIVE & GUARD-	330 LBS
BLOWER	- LBS
MOTOR & S.B.	- LBS
SILENCER	- LBS
FILTER	- LBS
<b>TOTAL WEIGHT</b>	<b>- LBS</b>

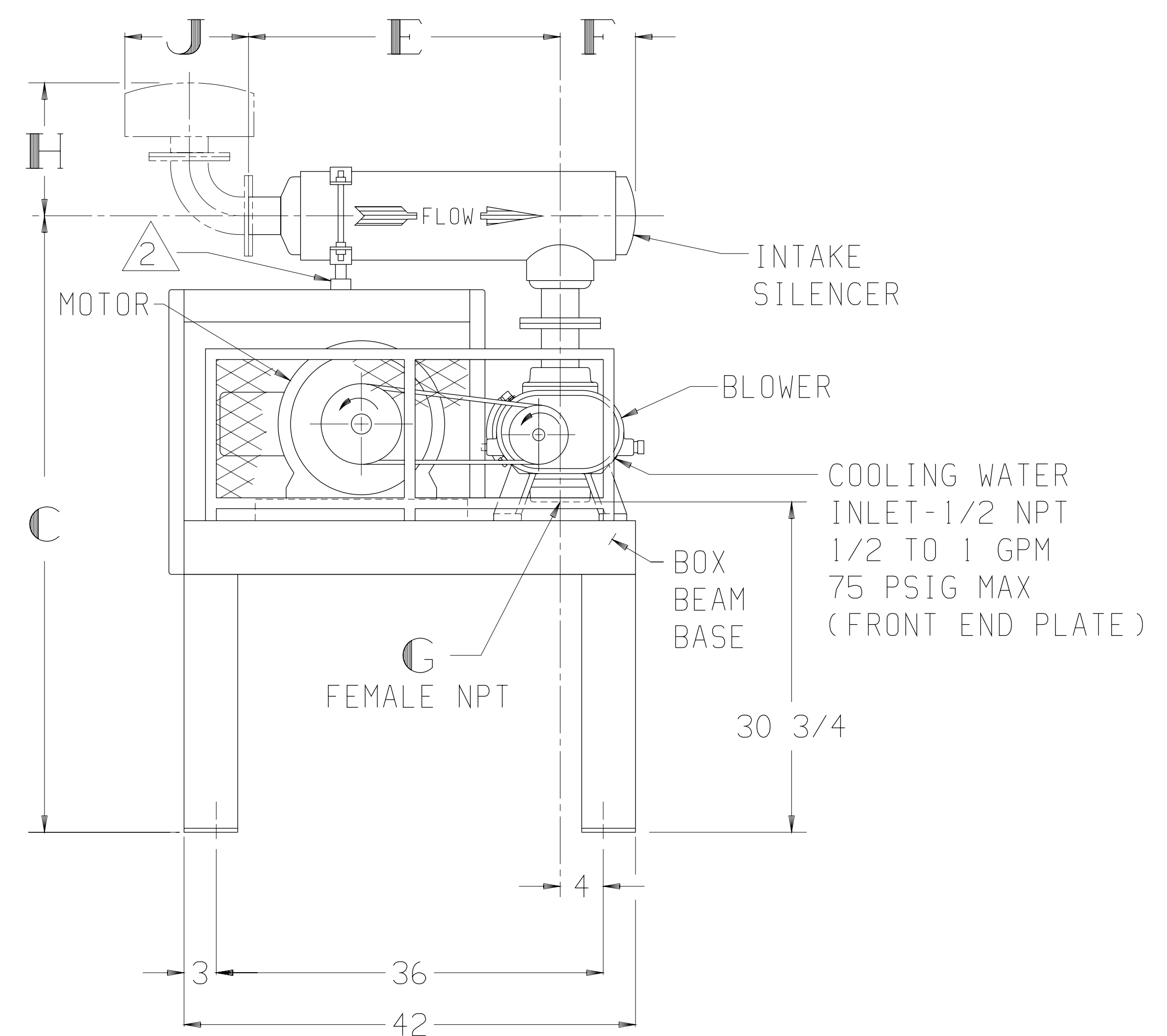
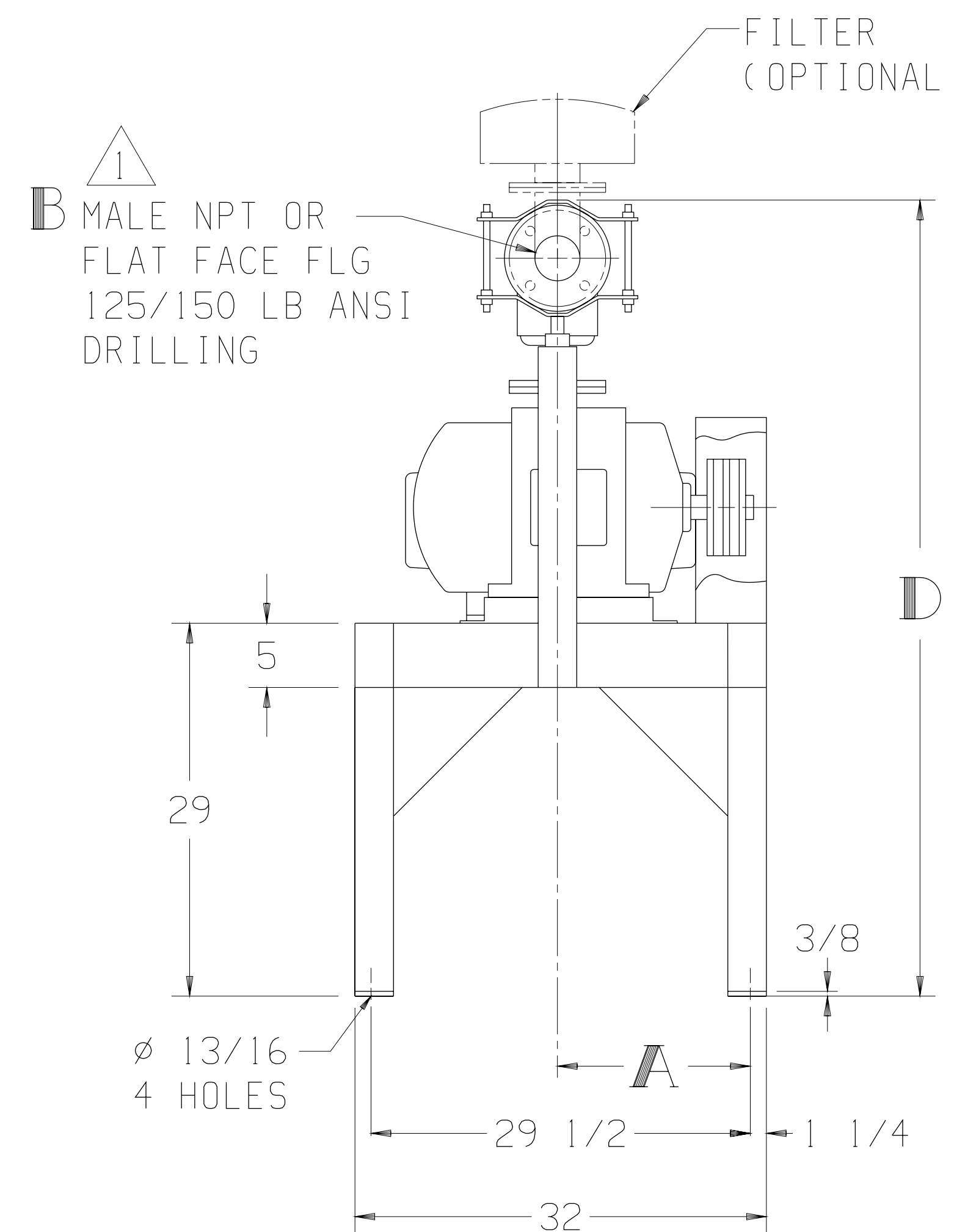

NOTE:

1 CONNECTION SIZE SHOWN IN TABLE ABOVE IS A STANDARD CONNECTION. WHEN REQUESTED, A CONNECTION OTHER THAN STANDARD CAN BE SUPPLIED. IF SO, IT IS \_\_\_\_\_ INLET CONNECTION.

2 AN "X" IN A PART NUMBER INDICATES NEEDED INFORMATION FOR A COMPLETE PART NUMBER



BASE MOUNTED OUTLINE B4000VV2A-ISE

SIZE:  
C2

DR LB 7-6-94

CH LB 7-6-94