

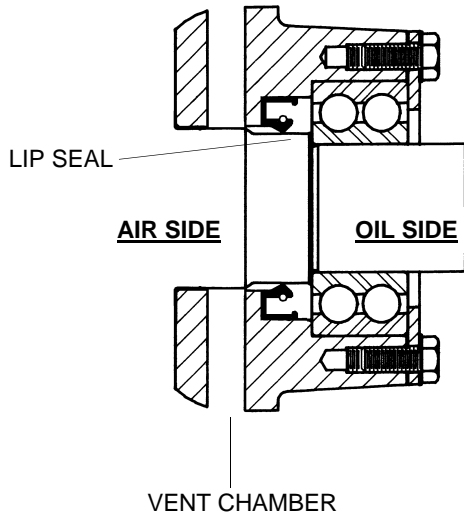

TECHNICAL BULLETIN #13

Typical Seal Configurations



LIP SEAL CONFIGURATION

COMPETITOR PLUS™ -21 SERIES DOMINATOR™ - 22 SERIES

In this configuration, a close fit between the rotor shaft and the end plate bore relieves pressure on the oil lip seal.

Small amounts of air are leaked between the end plate and rotor shaft to atmosphere. This prevents the lip seal from exposure to pressure or vacuum from the air side, allowing process pressure up to 15 PSIG or vacuum up to 16" Hg.

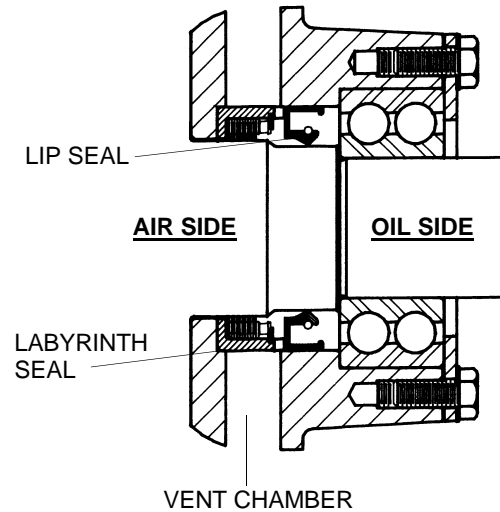

LABYRINTH-LIP CONFIGURATION

PD PLUS® 17/46 SERIES

In this configuration, the labyrinth seal, consisting of a series of evenly spaced Teflon® rings, each contacting the spinning rotor shaft, reduces the risk of dust or other debris which may be entrained in the process air stream from contacting the oil lip seal.

A small quantity (normally .75 to 3 CFM, depending on the model size) of air is leaked past the labyrinth seal to atmosphere through the vent chamber. This prevents the lip seal from exposure to pressure or vacuum from the air side, allowing process pressure up to 20 PSIG or vacuum up to 20" Hg.



TECHNICAL BULLETIN #13

Typical Seal Configurations

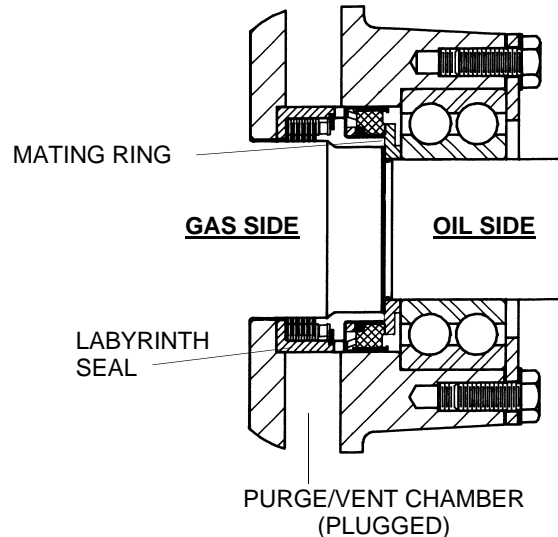

LABYRINTH-MECHANICAL CONFIGURATION

PD PLUS® 55/57/81/82 & 64/65/66/67/68/69 SERIES VACUUM BOOSTERS 31/33/90/91 SERIES

In this configuration, the labyrinth seal, consisting of a series of evenly spaced Teflon® rings, each contacting the spinning rotor shaft, reduces the risk of dust or other debris which may be entrained in the process gas stream from contacting the elements of the mechanical seal. The labyrinth seal also serves as a secondary seal for optional purging of the vent area.

In the mechanical seal, the mating surfaces of the stationary stator and rotating mating ring are lapped to optical quality flatness (within 3 helium light bands), providing near positive gastight sealing. A thin film of oil lubricates the dynamic sealing surfaces, and dissipates generated heat to optimize seal life. The wave spring maintains a constant compressive force between the sealing surfaces independent of process pressure or other external oil pressure. The O-ring provides internal sealing of the stator to prevent leakage of the process gas between the carbon face and the seal case. The outer diameter of the seal case is sealed to the end plate bore by either sealants or O-rings, depending on the gear size.

To reduce ingress of purge gas into the process area, the flow of purge gas can be regulated to provide nearly zero positive flow. In the case of varying pressures, differential pressure instrumentation can be utilized to optimize flow of purge gas.

All 60 series double envelope gastight and 31/33/90/91 series vacuum boosters can have the end covers pressurized or "blanketed" with inert gas to direct any leak path into the process chamber. Instrumentation can be used to monitor blanket pressure.

All Tuthill Pneumatics mechanical sealed blowers can be operated at pressures up to 100 PSIG. Pressures above 25 PSIG require hydrostatic testing and high pressure seal leakage testing.



TECHNICAL BULLETIN #13 **Typical Seal Configurations**

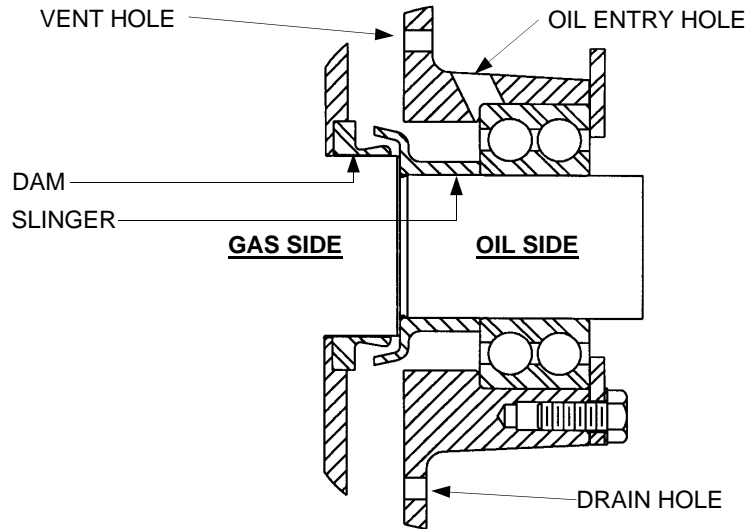

SLINGER SEAL CONFIGURATION **VACUUM BOOSTERS 35/37/92/93 SERIES**

This seal arrangement is an option to the labyrinth-mechanical arrangement for vacuum boosters. The vent chamber area of the end plate is opened to the oil sump compartment by the addition of vent and drain holes. The stationary dam and rotating slinger effectively redirect oil away from the gas area either back through the bearing or through the drain back into the oil sump. The vent hole is necessary for initial booster pump down, allowing the air or gas in the end covers to be evacuated without also drawing in the lubricant. Since the dam and slinger never make contact, the slinger seal is non-wearing.

All slinger seal boosters include mechanical seals on the drive shaft.

The advantage of this seal arrangement is the elimination of internal mechanical seals, resulting in less frequent overhauls.