

TECHNICAL BULLETIN #37

Truck Blower Rotation

With Tuthill's directional blowers, such as the T650, the blower must be turned in the direction marked on the front cover of the blower. For further clarification see the image below:

Blower CCW

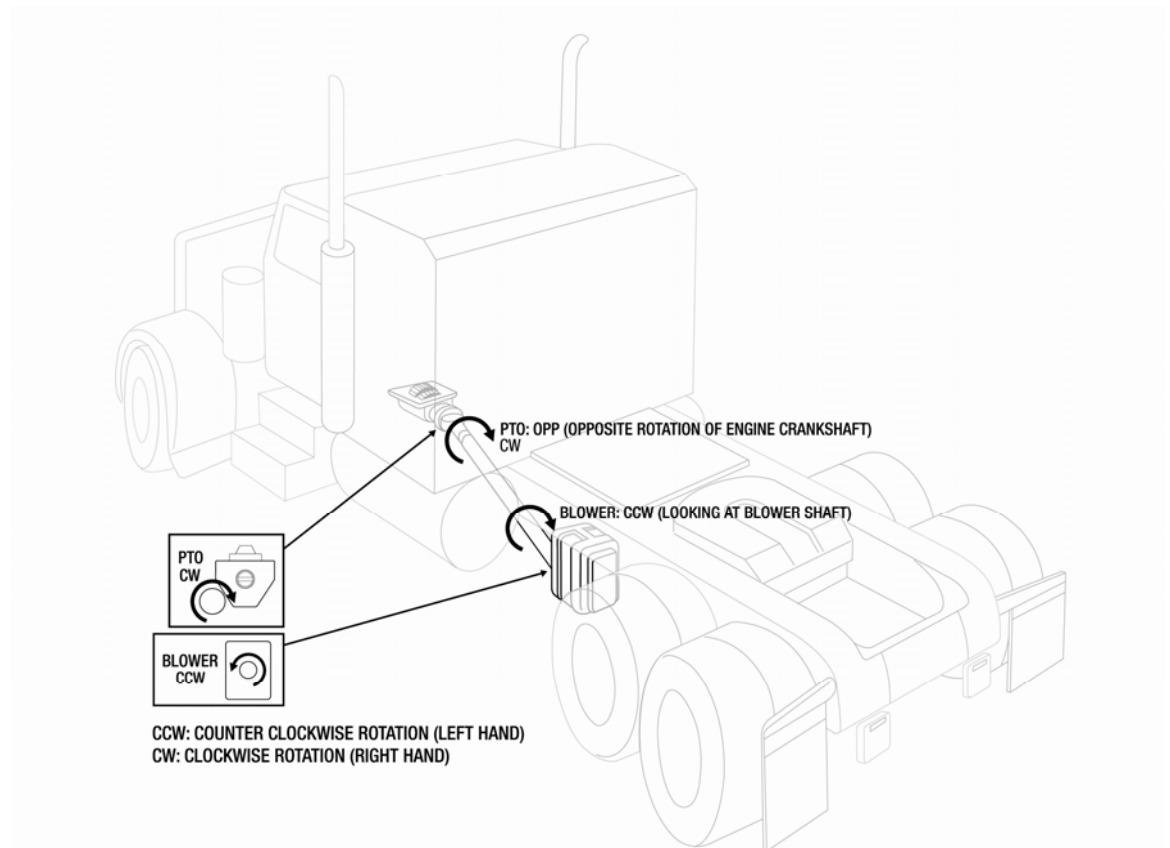

NOTE: Blower rotation is determined by looking at the blower shaft.

Blower CW

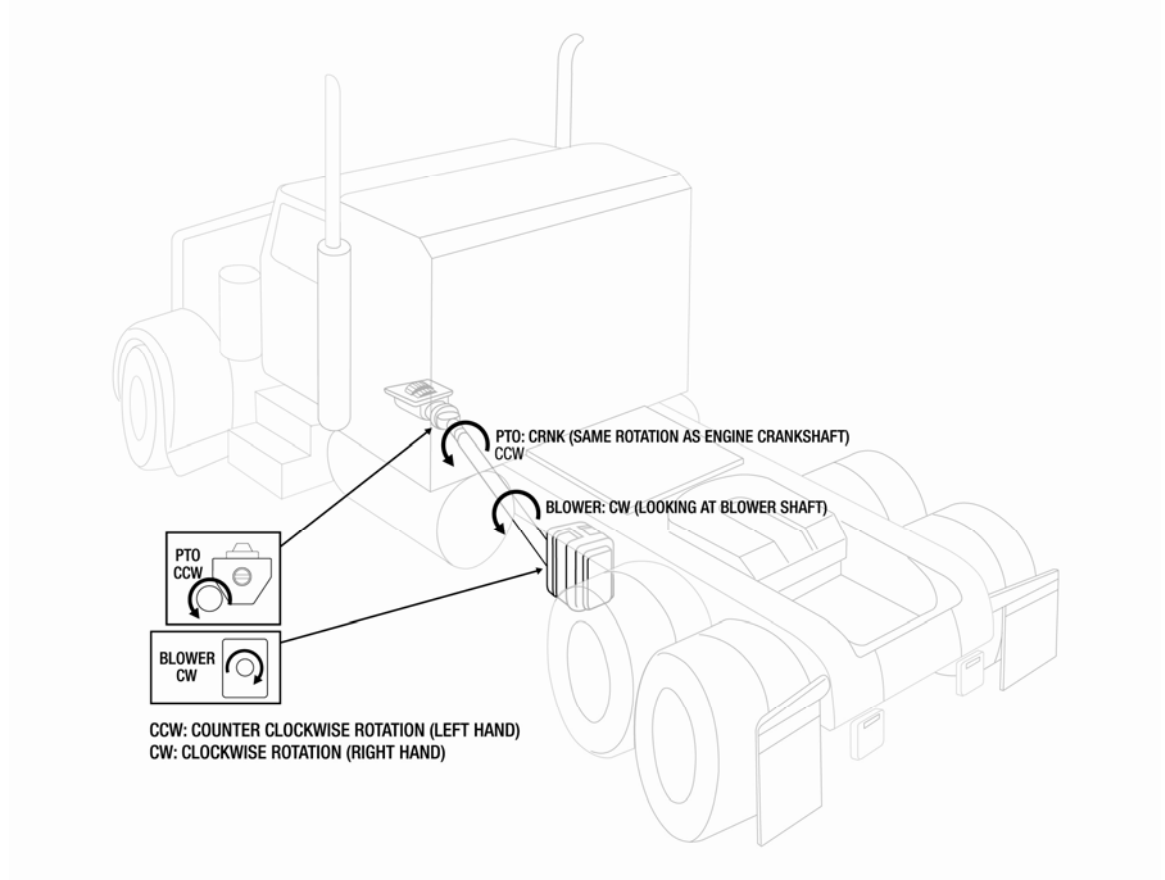

NOTE: Blower rotation is determined by looking at the blower shaft.