

M-D Pneumatics™

BLOWERS & VACUUM BOOSTERS



TUTHILL
Vacuum & Blower Systems



Competitor® Plus™

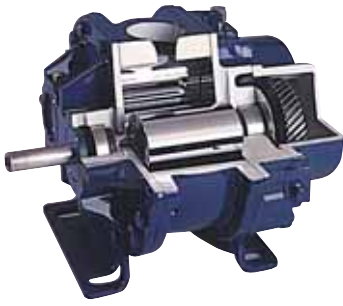

Competitor Plus blowers include special features usually found only on premium blowers—and at competitive prices. They are generally interchangeable with Roots Universal RAI® and many Sutorbilt® California Legend™ models, and compatible with most existing OEM engineering dimensions. Competitor Plus blowers are rated up to 15 PSIG (1.03 bar g) discharge pressure or 16" Hg (540 mbar g) dry vacuum.

Typical Applications:

Carpet Cleaning
Dairy Milking
Mosquito Fogging
Air Sparging
Wastewater Aeration
Compost Aeration
Vacuum Cleaning
Dust Collection

Model	CFM / m ³ /h	HP / kW
2002	6-76 / 10-129	0.3-4.9 / 0.2-3.7
2004	21-156 / 36-265	0.4-5.6 / 0.3-4.2
3002	20-155 / 34-264	0.4-12 / 0.3-9
3003	28-205 / 48-349	0.5-12 / 0.4-9
3006	57-344 / 97-585	0.7-12 / 0.5-9
4002	17-206 / 29-350	0.4-15 / 0.3-11
4005	39-410 / 66-697	0.6-24 / 0.5-18
4007	52-542 / 88-921	0.8-18 / 0.6-19
5003	38-355 / 65-604	0.6-25 / 0.5-19
5006	63-594 / 107-1010	0.9-37 / 0.7-28
5009	125-881 / 213-1498	1.2-29 / 0.9-22
6005	70-545 / 119-927	1.1-39 / 0.8-29
6008	112-875 / 190-1488	1.5-58 / 1.1-43
6015	261-1639 / 444-2786	2.6-54 / 2.0-40
7006	152-787 / 258-1338	1.6-55 / 1.2-41
7011	321-1449 / 546-2463	2.6-67 / 2.0-50
7018	762-2240 / 1295-3808	4.1-65 / 3.0-48

Competitor® SL™/GT™



Competitor SL rotary air blowers are designed with features ordinarily found on premium grade blowers—such as splash lubrication throughout, double-row ball bearings for durability and helical timing gears for quiet operation.

From the leader in gas blower technology, **Competitor GT** rotary gas blowers incorporate the features of our Competitor SL models and also include the field-proven cartridge type, balanced mechanical seals featured in our PD Plus® gas-tight models.

Upgrading to Competitor SL/GT is simple, since models are designed to be generally interchangeable, with respect to footprint, shaft height, diameter and port size with equivalent sizes of Universal RAI® & RAI-G™, and most Legend™ models.

Many Competitor SL/GT models are available with special noise reduction features including tri-lobe rotors and specially tuned and ported housings designed to eliminate noise before it starts.

Typical Applications: (Competitor SL)*

Dairy Milking
Mosquito Fogging
Air Sparging
Wastewater Aeration
Compost Aeration
Vacuum Cleaning
Dust Collection
Carpet Cleaning

Typical Applications: (Competitor GT)

Soil Vapor Extraction
Closed Loop Pneumatic Conveying
Coal Bed Methane Gas Extraction
Natural Gas Boosting

Model	CFM / m ³ /h	HP / kW
3003	28-196 / 48-333	1.7-13 / 1.3-10
3006	60-350 / 102-595	2.1-15 / 1.6-11
4005	36-383 / 61-651	1.8-22 / 1.3-16
4007	53-494 / 90-840	2.0-20 / 1.5-15
5006	57-580 / 97-986	1.9-38 / 1.4-28
5009	98-891 / 167-1515	2.6-36 / 2.0-27

*Certain custom configurations of Competitor SL models are contractually excluded from the carpet cleaning industry.

Equalizer®

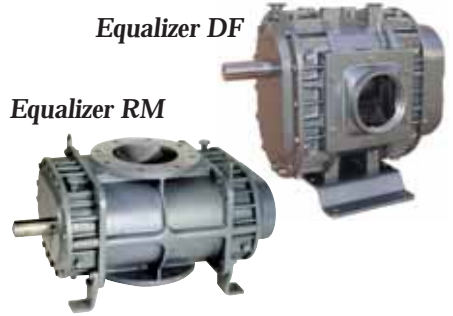

Our **Equalizer** family of blowers also includes special features usually found only on premium blowers, but at competitive prices. They are medium duty, compact blowers that are available in popular 4.5" and 6" gear diameters.

Typical Applications:

Pneumatic Conveying
Dairy Milking
Carpet Cleaning
Wastewater Aeration
Compost Aeration
Vacuum Cleaning
Dust Collection
Mobile Vacuum Waste Removal

Equalizer RM models are designed to interchange with competitive RCS®/RAM™ models.

Model	CFM / m ³ /h	HP / kW
4606	85-645 / 145-1097	2.0-58 / 1.5-43
4609	129-946 / 219-1608	2.4-82 / 1.8-61
4612	173-1253 / 294-2130	2.8-90 / 2.0-67
* 6012	350-1667 / 595-2834	4.2-119 / 3.0-89
6016	494-2232 / 840-3794	5.2-157 / 3.9-117
6024	830-3358 / 1411-5709	7.2-157 / 5.4-117

* 6012 model is interchangeable with Sutorbilt® 612-4500

Equalizer DF models are designed to interchange with competitive DuroFlow® models and equivalent products manufactured by others.

Additionally, Equalizer DF models bolt right in to your existing DuroFlow ports to provide maximum flexibility for your specific installation. Individual ports are also available for your Equalizer DF.

Model	CFM / m ³ /h	HP / kW
4504	39-416 / 66-707	1.7-39 / 1.3-29
4506	82-619 / 139-1052	1.9-56 / 1.4-42
4509	125-919 / 212-1562	2.3-80 / 1.7-59
4512	169-1226 / 287-2083	2.7-88 / 2.0-66

PD Plus®



PD Plus is a long-established line of premium, heavy-duty models ranging from 3.25" to 12" gear diameter and 2.5" to 48" rotor length. These blowers are renowned for their quality, dependability and outstanding performance.

Typical Applications:

Soil Vapor Extraction
 Non-Sparking Requirements or Process
 Oil-Free Handling Fuel, Utility Processing Gases
 Pulp/Paper Processing
 Laser Re-Circulation Systems
 Fluid Bed Combustion
 Pneumatic Conveying
 Fluidization/Agitation of Dense Powders
 Supercharging Compressors
 Vapor Recovery
 Digester Gas Processing
 Steam Compression
 Mobile Vacuum Waste Removal
 High-Performance Applications
 Carpet Cleaning
 Pressure Boosting to 100 PSIG (6.9 bar g)

Model	CFM / m ³ /h	HP / kW
3202	8-90 / 14-153	0.8-8.6 / 0.6-6.4
3204	12-146 / 20-248	0.9-13 / 0.7-9.7
3206	21-220 / 36-374	1.0-18 / 0.8-3.0
3210	37-368 / 63-626	1.2-28 / 0.9-21
4006	39-338 / 66-575	1.5-30 / 1.1-22
4009	49-497 / 83-845	1.7-45 / 1.3-34
4012	87-682 / 148-1159	2.0-51 / 1.5-38
5507	99-794 / 168-1350	2.5-70 / 1.9-52
5509	128-956 / 218-1625	2.7-84 / 2.0-63
5511	152-1171 / 258-1991	3.0-96 / 2.2-62
5514	490-1522 / 833-2587	3.5-95 / 2.6-71
5516	277-1743 / 471-2963	3.8-100 / 2.8-75
5518	350-1962 / 595-3335	4.1-94 / 3.0-70
5520	435-2185 / 740-3715	4.5-84 / 3.3-63
7010	349-1690 / 593-2873	4.3-143 / 3.2-107
7013	445-2148 / 757-3652	6.0-183 / 4.5-136
7017	601-2807 / 1022-4772	7.2-226 / 5.4-169
7021	783-3478 / 1331-5913	8.3-244 / 6.2-182
7026	1052-4314 / 1788-7334	9.8-242 / 1.3-180
9012	266-2277 / 452-3871	4.6-163 / 3.4-122
9016	354-3028 / 602-5148	5.5-215 / 4.1-160
9020	465-3986 / 791-6776	6.5-280 / 4.8-209
9027	620-5315 / 1054-9036	8.0-371 / 6.0-276
1215	284-3764 / 483-6399	6.3-271 / 4.7-202
1224	494-6036 / 840-10261	8.6-427 / 6.4-318
1230	618-7546 / 1051-12828	10-496 / 7.5-370
1236	771-9065 / 1311-15411	12-385 / 9.0-287
1248	1304-9273 / 2217-15764	15-267 / 11-199

TI850



The **TI850** heavy-duty industrial blower is designed for high performance applications up to 20 PSIG continuous capacity. It features a rugged design for heavy-duty applications, noise reduction from specially designed ports, convenience with removable 4" NPT port flanges, durability from double row ball bearings and is field convertible from horizontal to vertical flow.

Typical Applications:

Pneumatic Conveying
 Vacuum Cleaning

Model	CFM / m ³ /h	HP / kW
TI850	181-944 / 307-1604	10-97 / 7.5-72.4

Vacuum Boosters



M-D Pneumatics™ Vacuum Boosters provide low-cost, high-capacity gas volumes at high vacuums (50 Torr to micron range) and may be used in conjunction with all types of vacuum pumps. All units are dynamically balanced and leak tested.

Typical Applications:

Supercharging Vacuum Systems
 Vacuum Drying
 Dehydration
 Packaging

Model	CFM / m ³ /h
3204	50-160 / 85-272
3206	70-240 / 119-408
3210	120-400 / 204-680
4009	170-540 / 289-918
4012	230-720 / 391-1224
5507	270-800 / 459-1360
5509	330-1000 / 561-170
5511	400-1200 / 680-2040
5514	500-1600 / 850-2720
5518	650-2000 / 1105-3400
5524	850-2700 / 1445-4590
7010	680-1800 / 1156-3060
7013	860-2300 / 1462-3910
7017	1130-3000 / 1921-5100
7021	1400-3600 / 2380-6120
7026	1730-4600 / 2941-7820
9012	600-2300 / 1020-3910
9016	800-3100 / 1360-5270
9020	1040-4100 / 1768-6970
9027	1390-5500 / 2363-9350
9036	1820-7300 / 3094-12410
1215	880-4000 / 1496-6800
1224	1410-6200 / 2397-10540
1230	1770-7800 / 3009-13260
1236	2120-9400 / 3604-15980
1248	2830-12700 / 4811-21590



PneuMax™ and **PneuPak™** are dependable and economical low pressure (up to 15 PSIG [1.03 bar g] or 16" Hg [540 mbar g] vacuum) air sources for many industrial and municipal applications such as pneumatic conveying of bulk powder, seed or other granular material, fluidization/agitation of bulk powders, wastewater aeration, and motive force for vacuum exhausting, dairy milking and central vacuum systems.

PneuMax boasts a small package footprint with integral noise control enclosure for guaranteed* open field noise performance of 85 dB(A) at 1 m., as well as built-in instrumentation, check and pressure relief valves. With typical availability of less than one week after receipt of order, PneuMax gets air to your system FAST.

PneuPak provides a conventional, vertical flow design with an integral silencer/base combination, and is compact in terms of floor space.

* Noise guarantee is limited to test results collected at Tuthill Vacuum & Blower Systems facility, Springfield, Missouri USA, on a single PneuMax unit operating at maximum rated blower speed, and maximum rated blower pressure, with average of measurements taken at 1m distance, 1.5m above floor not to exceed 85 dB(A). Due to the many uncontrollable variables associated with individual installations, installed noise levels cannot be guaranteed.

M-D Standard Packages

You may also choose from a complete line of other Standard Blower Packages, utilizing PD Plus®, Equalizer® or AcousticAir™ blowers ready for delivery in as little as two weeks. Standardized designs allow numerous combinations. Certified engineering drawings are immediately available for customer layout and piping design work.

Custom Engineered Packages

If you have a special application requiring a custom engineered blower package, we are eager to design and manufacture one specifically to your needs.

Blower design, materials of construction, seals, and all auxiliary components can be selected to ensure performance and compatibility with the type of product and operating conditions of your application.

Tuthill Vacuum & Blower Systems can supply custom packages with two-stage blowers, high vacuum boosters, special lubrication systems, liquid injection systems, plus much more.

- Flows from 200 - 9000 CFM (340 - 15300 m³/h)
- Pressure to 100 PSIG (6.9 bar g)
- Vacuum to one micron (0.13 Pa)
- Approval drawings provided

Single Source Factory Warranty

Because we design, engineer and build our own blower packages, we warrant the entire package, including its components.

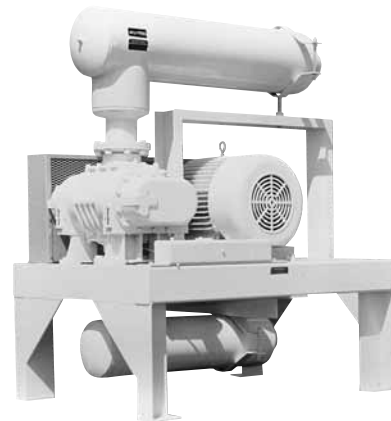

Leading the Search for Innovative SolutionsSM

Whether you need rotary positive displacement blowers, blower packages or mechanical vacuum boosters, Tuthill Vacuum & Blower Systems (TVBS) is leading the search for innovative solutions. Since 1937, TVBS has been designing and manufacturing proven M-D Pneumatics products that are solidly engineered, competitively priced and produced under stringent ISO 9001 quality standards.

Our experience has helped us to establish a worldwide customer base and made us one of the industry's leading manufacturers of rotary lobe blowers and vacuum boosters. Our commitment to delivering the right solution at the right time continues to guide how we do business now and in the years to come.

For new blower applications or replacements, TVBS offers one of the broadest lines of positive displacement blower models and vacuum boosters in the industry. Each blower and booster is tested before shipping and carries a factory warranty. Applications include pneumatic conveying, chemical processing, gas moving, vacuum boosters or exhausting, food processing, waste treatment aeration, elevated pressures, complete package systems, and more.

Typical M-D Pneumatics Features

- Five bearings, including one outboard on the shaft for durability
- Helical timing gears are quieter, stronger and easier to time; mounted on drive end to reduce torsional load on rotors
- Oil sumps on both ends for better lubrication and reliability
- Extra heavy castings for durability and heat absorption, high pressure
- Every unit production tested before shipment

Two or Three Lobe Rotors
Multiple Seals
Five Bearings
Heavy-Duty Housing
Two Oil Sumps
Flush Ground Bearings
Helical Timing Gears

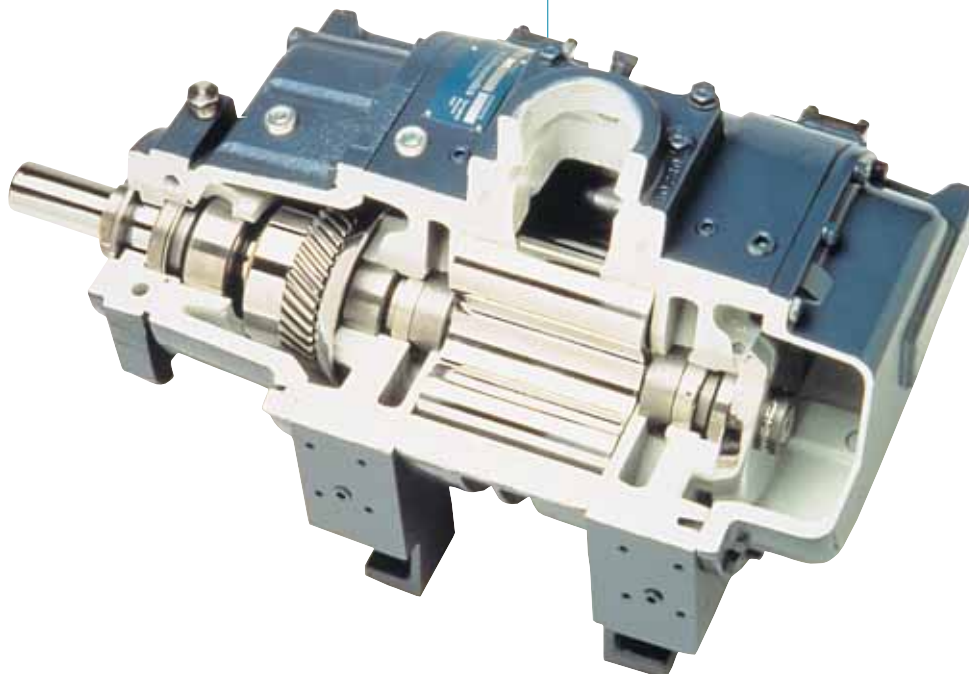

Tuthill Vacuum & Blower Systems

Since 1937, Tuthill Vacuum & Blower Systems has been a major manufacturer of rotary positive displacement blowers. In 1969, the company was relocated to a modern facility in Springfield, Missouri. Springfield was chosen for its central US shipping location, availability of quality castings, work ethic of the labor force, and favorable business climate.

Modern Tuthill Vacuum & Blower Systems facilities in Europe, Argentina, Asia, and Australia, including a dedicated Latin America sales team, illustrate our growing commitment to our international blower business. These facilities enhance our resources by offering additional manufacturing capacity, sales and distribution. The result of these combined resources is a broad product line of reliable industrial blowers, for both pressure and vacuum applications, delivered on time, at a fair price.

Quality Assured

Every M-D Pneumatics™ blower manufactured by Tuthill Vacuum & Blower Systems is test run before it leaves the factory. Tuthill Vacuum & Blower Systems Quality Assurance Program is ISO 9001 registered.

Quick Delivery

A complete network of sales representatives and stocking locations assure rapid availability.

Outstanding Service

For responsive service, parts, application assistance, or special requirements, contact your local Tuthill Vacuum & Blower Systems sales professional.

Factory Warranty

Tuthill Vacuum & Blower Systems will repair or replace defective equipment or parts according to the terms of its limited warranty.

How to Order or Obtain Information

To place an order or obtain additional information contact your local Tuthill Vacuum & Blower Systems sales professional. For the name of the local sales professional in your area, call our customer service number at (800) 825-6937, or visit us online at <http://vacuum.tuthill.com>.

For International Sales, Contact:

		Telephone	Fax
Tuthill Latin America	Coral Gables, Florida	(305) 740-3381	(305) 740-9328
Tuthill Europe	Wavre, Belgium	32-10/22.83.34	32-10/22.83.38
Tuthill Argentina	Quilmes (Buenos Aires)	54-11-4-253-7007	54-11-4-257-2457
Tuthill Asia Pacific	Kilsyth, (Melbourne), Victoria	61-3-9720-6533	61-3-9720-6880
	Shanghai, China	86-21-6853-4698	86-21-5885-8719



Your Local Tuthill Vacuum & Blower Systems Sales Professional Is:



TUTHILL
Vacuum & Blower Systems

4840 West Kearney Street
Springfield, Missouri USA 65803-8702
417-865-8715 • 1-800-825-6937 • Fax: 417-865-2950
<http://vacuum.tuthill.com>

M-D Pneumatics™ Blowers and Vacuum Boosters



ISO 9001 is the most comprehensive standard issued by the International Organization for Standards applicable to quality for engineering, production and service.

Tuthill Vacuum & Blower Systems is one of a relatively few manufacturing companies to have qualified for this certification.